

SAILING INSTRUCTIONS

SNIPER CLASS INTERNATIONAL RACING ASSOCIATION-USA
2013SCIRA-USA Women's National Championship
November 23-24, 2013
Lauderdale Yacht Club
Ft. Lauderdale, Florida

Rules:

- 1.1 The regatta 2013SCIRA-USA Women's National Championship is governed by:
- a) The rules as defined in the current Racing Rules of Sailing
 - b) No current *US Sailing Prescriptions* will apply, with the exception of 40, 67, 70.5 and 76.1.
 - c) The current SCIRA Class Rules, By-Laws, Rules of Conduct for National and International Championships
 - d) The trophy restrictions for the SCIRA-USA Women's National Championship and its Deed of Gift. Any conflict arising between Deed of Gift and the SCIRA Rules of Conduct shall be solved by the application of The Deed of Gift
 - e) In case of conflict between the Notice of Race or the ROC's and the Sailing Instruction, the Sailing Instructions shall prevail.
 - f) RRS 35 are changed herein to provide that boats not finishing within 30 minutes after the first boat to finish will be scored TLE and scored as one (1) more place than the last boat to finish, without a hearing.
 - g) RRS 62.2 and 66 are changed herein to shorten the time for requesting redress and for requesting that a hearing be re-opened on the last day of racing.
 - h) RRS 30.3 will not be used.
 - i) RRS 32.2 and 33 will be changed herein to limit course changes
 - j) RRS 60.1(a) is changed herein to restrict protest from boats for specific items on the NOR and SI.
 - k) RRS 64.2 is changed herein to compel the Jury/PC to abandon a race as required by ROC 18.

Entry and Eligibility:

- 2.1. The penalty breaking rule 75.2 with reference to Regulation 19, Eligibility Code shall be a warning.
- 2.2 As per the Deed of Gift at "Eligibility," section 2, the event is open to any female skipper and female crew, who are both current SCIRA class members, from any Country that is in good standing with SCIRA.
- 2.1 As per the Deed of Gift at "Eligibility," section 2.1, boats shall be deemed eligible to sail in the USA Women's National Championship when they have been registered with the class and display a valid SCIRA decal on the hull. This shall supersede the SCIRA Rules for Running Championship Regattas.
- 2.3 The same crew shall race in all races, except for reasons satisfactory to the Race Committee. Requests for a change of crew shall be submitted in writing to the Chairman.
- 2.4 Once a crew has been excused, he/she may not return for the balance of the series.
- 2.5 The Race Committee may inspect competitors or boats not racing at that time.
- 2.6 Bow numbers may be used, depending on the number of pre-registrants. If used, bow numbers are assigned at registration and it shall be each competitor's sole responsibility to properly affix them in conformance with the instructions and to properly maintain them. Any boat that is determined by the Race Committee to have violated this instruction may be protested. The penalty shall be the 10% scoring penalty for the first race competed in by the infringing boat on the day of infraction. Replacement numbers shall be available from the Race Committee.

Advertising:

- 3.1 Advertising is permitted as per Snipe Class rules.
- 3.2 Boats may be required to display advertising chosen and supplied by the organizing authority

Notices to Competitors:

- 4.1 Notices to competitors will be posted on the official regatta notice board located at the Lauderdale Yacht Club Sailing Center.
- 4.2 Any change to the sailing instructions will be posted before 0900 hrs. on the day it will take effect, except that any change to the schedule of races will be posted by 1800 hrs. on the day before it will take effect.
- 4.3 Any change or amendment to the Sailing Instructions shall be approved by the SCIRA Representative.

Competitor’s Meeting/Signals made Ashore:

- 5. There will be a competitors’ meeting at 0930 hrs. at the LYC Sailing Center on Saturday, November 23, 2013, and announced by two sound signals.
- 5.1 Signals made ashore shall be displayed at the LYC flag pole on the east lawn.
- 5.2 When Flag “AP” is displayed ashore, “1 minute” is replaced with not less than 60 minutes after the “AP” is lowered.
- 5.3 When Flag “D” is displayed, it means: “Boats are not allowed to leave the harbor/shore until the flag is removed.” The warning signal will be made not less than 60 minutes after the “D” Flag is lowered.

Schedule of Races:

<u>Day and Date</u>	<u>Time of Warning Signal</u>
Saturday, Nov. 23, 2013	1100 hrs.
Sunday, Nov. 24, 2013	1100 hrs.

- 6.1 The Race Committee shall attempt to complete six races.
- 6.2 As per the Deed of Gift at “Regatta Conditions,” section 3, a minimum of three (3) races are to be sailed to constitute a regatta.
- 6.3 As per the Deed of Gift at “Regatta Conditions,” section 3.3, in the event that more than five (5) total races are to be sailed, more than three (3) races are permitted to be sailed in a single day. This provision supersedes the SCIRA Rules of Conduct.
- 6.4 On the last day of the regatta no warning signal will be made after 1430 hrs.

Racing Area:

- 7. The Racing Area location is approximately one nautical mile south of the Port Everglades Inlet, just to the north of the Dania Pier.

Courses:

- 8.1 Courses used shall be one or more of those shown in the attached diagrams and shall be:

Course Signal Flag	Course Description
“W”	Windward, Leeward Course, two laps, finish to Windward
“O”	Olympic Course, Triangle, Windward, Leeward, finish to Windward
“T”	Double Triangular Course, two laps, finish to Windward
“WD”	Windward, Leeward twice around, finish downwind
“OD”	Triangle, Windward, Leeward, finish downwind
“TD”	Two lap, Triangular Course, finish on the second lap, second reach

The attached course diagrams indicate the order in which marks are to be rounded and the side on which each mark is to be left. This changes SCIRA Rules of Conduct 5.

- 8.2 The approximate compass bearing to Mark W shall be displayed on a board on the Race Committee Signal Boat before the Warning signal.
- 8.3 The Course Signal Flag(s) shall be hoisted not less than one minute before the warning signal and will remain displayed for at least ten minutes after the start or approximately one minute before the starting sequence of the next Class, if applicable, whichever occurs first.

- 8.4 As per the Deed of Gift, "Regatta Conditions," Section 3.1, the first leg of each race shall not have a defined minimum length. This shall modify the SCIRA Rules for Running Championship Regattas, clause 5.
- 8.5 In case of Windward-Leeward course (code flag W) offset mark(s) shall be set adjacent to Mark 1 (windward) and/or Mark 3 (leeward) The race committee may remove without signal any offset mark prior to the lead boat rounding the adjacent primary or new mark.

Marks:

- 9.1 Marks "W," "R," and "L" will be orange tetrahedrons.
- 9.2 New marks used in accordance with Change of Course after the Start shall be yellow tetrahedrons.
- 9.3 The start mark and finish mark will be yellow tomato shaped marks.
- 9.5 The Race Committee Signal Boat may set a buoy attached to its stern. The buoy and its line, or attachment mechanism, are parts of the mark for purposes of RRS 31.

The Start:

- 10.1 Races will be started in accordance with RRS 26
- 10.2 The starting line will be between an orange flag on the Race Committee Signal Boat at the starboard end and the course side of the port end starting mark. The official Class Flag shall be a Snipe Class Flag.
- 10.3 A boat will not start more than five minutes after her starting signal. Any boat starting later than five minutes will be scored Did Not Start (DNS) without a hearing.

Reporting at Starts:

- 11.1 Before the warning signal of the first race of each day, each boat is required to sail past the stern of the Race Committee Signal Boat on starboard tack and verbally check in by bow number, if bow numbers are used; otherwise, check in shall be by sail number.
- 11.2 When the Race Committee verbally acknowledges a boat's number, the check-in has been officially noted.
- 11.3 Any boat failing to check in accordance with instructions 11.1 and 11.2 will receive a scoring penalty equal to 10% of the starters in the first race of the day. This changes RRS Appendix A4.1 and A5.

Recalls:

- 12.1 RRS 30.3 ("Black Flag Rule") shall not be used. This changes RRS 30.3
- 12.2 The Race Committee signal boat may post a list of OCS and/or ZFP boats. The failure to post the list or posting an incomplete or wrong list will not be grounds for a protest. The Race Committee will not individually provide the information, if the information is not posted.

Change of Course after the Start:

- 13.1 A change of course shall be signaled per RRS 33.
- 13.2 A leg of the course will not be lengthened or shortened more than 30% of the original leg length. This changes RRS 33.
- 13.3 Courses "W" and "WD" shall not be shortened to less than three legs; all other courses shall not be shortened to less than four legs. This changes RRS 32.1.

The Finish:

- 14.1 The finish line will be between an orange flag on a Race Committee boat and the course side of the finish mark for courses "W," "O," and "T."
- 14.2 For courses "WD," "TD," and "OD," the finish line shall be between a staff displaying an orange flag on the Signal Boat and the course side of the start mark, which mark may be moved closer to the Signal Boat than it was at the start.
- 14.3 When a change of course according to ROC 9.2 is displayed, the finish line will continue to be the same as the original course finish line. The Committee will not display code flag "D" when indicating a change of the course which originally had a downwind finish.

Time Limit:

- 15.1 Any boat on the course that has not finished within 30 minutes of the time of the first boat to finish shall be scored TLE (Time Limit Expired) without a hearing. This changes Rule 35.
- 15.2 The time limit for the first boat to complete the first lap is 40 minutes from the start. If the first boat fails to complete the first lap within 40 minutes, the Race Committee shall abandon the race. For the purpose of this Rule, a lap means the rounding of Mark "L" for the first time.
- 15.3 The time limit for the first boat to finish the race shall be 90 minutes.

Withdrawing from the Race:

- 16 A boat that exits the course shall notify the Race Committee at the first opportunity.

Protests and Requests for Redress:

- 17.1 Any boat intending to protest, or file a request for redress alleging that an action or omission on the part of Race Committee has materially prejudiced her finishing position, shall notify the Race Committee immediately after finishing that race. This modifies RRS 62.2
- 17.2 SI 17.1 does not apply to request of redress resulting from scoring, penalties applied without a hearing with rule 29 RRS, and 2.6 SI, or to request for redress with respect to alleged scoring errors.
- 17.3 Protests shall be made in writing on forms available at on the official regatta notice board and shall be delivered to the Jury within one half hour after the Signal Boat docks, which time will be posted on the official regatta notice board. This changes rule 61.3 and 62.2 RRS.
- 17.4 Within the protest time, the Race Committee shall post the bow numbers, if used, or sail numbers of all the boats that are disqualified or penalized under rules 29 and 30 RRS. A boat so notified may only file a request for a redress hearing within one half hour of that posting. This changes 62.2 RRS
- 17.5 A notice fulfilling the requirements of rule 63.2 RRS, and indicating the parties, time and order of hearings will be posted not later than one half hour following the expiration of the protest time limit.
- 17.6 On the last day of the regatta, a request for reopening a hearing shall be delivered:
 - (a) within the protest time limit if the party requesting reopening was informed of the decision on the previous day;
 - (b) No later than thirty (30) minutes after the party requesting reopening was informed of the decision on that day. This modifies rule 66 RRS
- 17.7 For the purpose of rule 64.3(b) RRS the "authority responsible" is the Measurer of the event and if none the SCIRA Rep for the event. .
- 17.8 Breaches of SI 2.6 (Bow Numbers), 21 (Support Boats), 23 (Insurance) and 24 (Disposal of Refuse) shall not be grounds for protest by a boat. This changes rule 60.1(a) RRS

Scoring:

- 18.1 The ISAF low point scoring system, Appendix A, modified as indicated herein to add TLE, will be used. TLE shall be scored as one more than the last boat to finish in that race. Boats not finishing within 30 minutes after the first boat to finish will be scored TLE without a hearing. This modifies RRS 35.
- 18.2 As per the Deed of Gift, "Regatta Conditions, section 3.2, if six (6) races are completed, the worst race shall be dropped, including a disqualification. If five (5) or fewer races are sailed, all shall be counted.
- 18.3 RRS 62 is modified such that a violation of RRS 29.1 (OCS) may not be dropped if unsuccessfully contested by the infringing competitor and shall be scored DNE.
- 18.4 A boat that has finished and submits in writing to the Jury that it retires from a race shall be scored RAF for that race.
- 18.5 Any boat failing to check in shall be ranked as a starter for scoring purposes.

Penalties:

- 19.1 Any competitor using a two turns penalty shall report that use to the Race Committee promptly upon finishing that race.

Team Racing:

- 20.1 The use of team racing tactics shall not be tolerated. If the Race Committee (acting under RRS 32.1(e)) or Protest Committee determines that the use of team racing tactics may have significantly influenced the outcome of a race they shall order that race abandoned and, if possible, re-sailed excluding the participation of the infringing boat(s). This modifies RRS 36. If the race is not re-sailed the infringing boat(s) shall be subject to protest and disqualification.

Support Boats:

- 21.1 Team leaders, coaches and other support personnel shall not go afloat in the racing area during the racing except upon Race Committee designated spectator boats. The Race Committee may initiate additional restrictions by posting them on the Official Notice Board.
- 21.2 Coaches may not communicate with competitors after the warning signal for any race until after the finish of the race. At the warning signal, coaches must be positioned at least 50 meters below the starting line. After the starting signal coaches may follow the fleet, but only on the port side of the course and must stay 50 meters from any mark. Failure to comply with these stipulations, at the discretion of the Race Committee, will result in denial in access of the coach boats.
- 21.3 Coaches shall check in with the LYC Marina Office that will provide for them an identifying flag. Coaches must have a working VHF, must monitor the regatta channel; must follow the directions of Race Committee personnel, and must not interfere with the racing; failure to do so may result in the disqualification of the coach's boats from the race in which the infraction occurs.

Disclaimer of Liability

- 22 Competitors participate in the regatta entirely at their own risk. See rule 4, Decision to Race. The organizing authority will not accept any liability for material damage or personal injury or death sustained in conjunction with or prior to, during, or after the regatta.

Insurance

- 23 Each participating boat shall be insured with valid third-party liability insurance with a minimum cover of (insert amount) per event or the equivalent.

Disposal of Refuse:

- 24 The discharge of refuse into the water is prohibited during the entirety of this event. Any boat observed to be in violation is subject to protest and may be assessed an infraction by the jury, or the jury may assign a scoring penalty other than disqualification for violation of Rule 55 (Trash).

Prizes:

- 25.1 Prizes shall be awarded to the skipper and crew for the top three places.
- 25.2 As per the Deed of Gift at section 1 and at "Eligibility," section 2, the Women's National Championship Award shall be awarded to the highest placing team in which both the skipper and crew are either Citizens or Residents of the United States for at least one (1) year. If a team with a skipper or crew from a country other than the United States wins the event, that team will be considered the event winner and eligible to compete in any event for which the US Women's National Championship is a qualifying regatta, but would not be the USA Women's Champion. This is not a Qualifier Regatta for any international championship this year
- 25.3 A prize shall be awarded to the top junior team, or if no junior team, to the top junior skipper. A junior is defined as a skipper not reaching the age of 22 or older in 2013.
- 25.4 A Sportsmanship Award will also be given to recognize a person who demonstrates Snipe spirit.

Signatures:

SCIRA REPRESENTATIVE, Martin Bebb

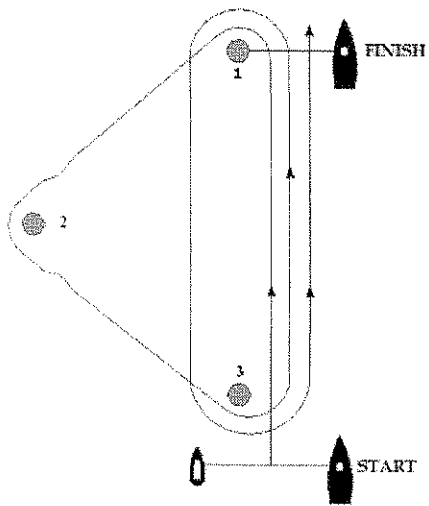

PRINCIPAL RACE OFFICER, Peter Commette

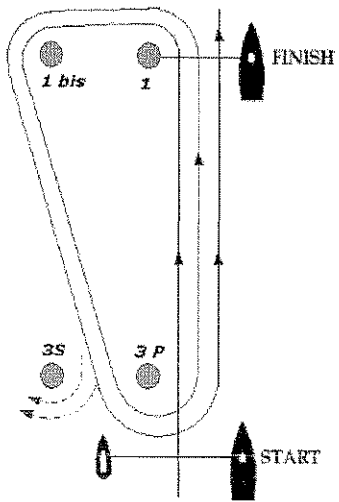

COURSE "O"
 START - 1-2-3-1-3- FINISH

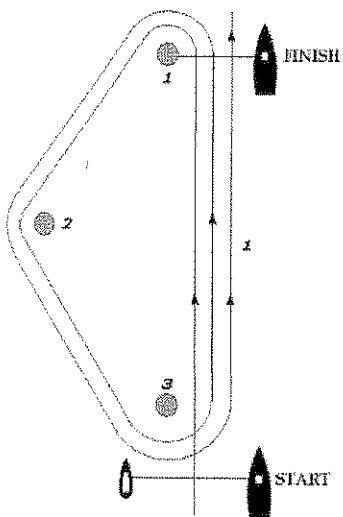

COURSE "W"
 START -1-OS 3S/3P-1-OS-3S/3P- FINISH



COURSE "T"
 START -1-2-3-1-2-3- FINISH

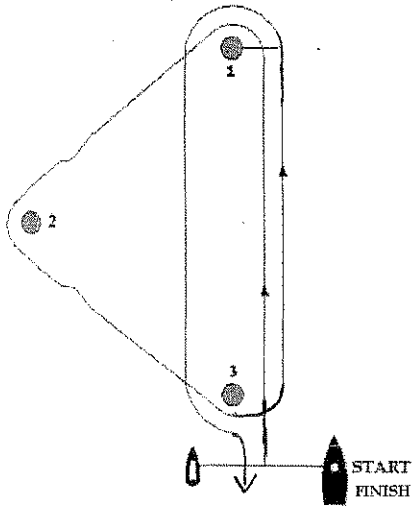

COURSE "OD"
 START - 1-2-3-1-3- FINISH

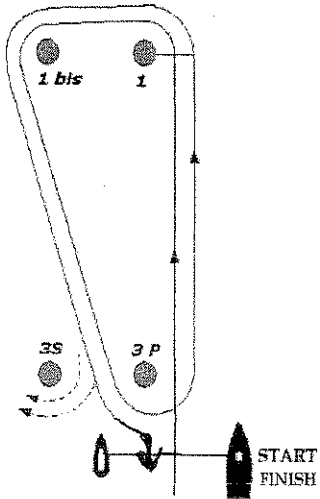

COURSE "WD"
 START -1-OS 3S/3P-1-OS-3S/3P- FINISH

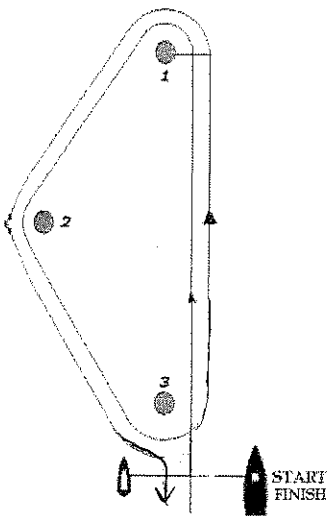

COURSE "TD"
 START -1-2-3-1-2-3- FINISH